

nexen.

AIR CHAMP® PRODUCTS



Single Post Caliper Brake VC500

In accordance with Nexen's established policy of constant product improvement, the specifications contained in this manual are subject to change without notice. Technical data listed in this manual are based on the latest information available at the time of printing and are also subject to change without notice.

Technical Support: 800-843-7445
(651) 484-5900

www.nexengroup.com



DANGER

Read this manual carefully before installation and operation.

Follow Nexen's instructions and integrate this unit into your system with care.

This unit should be installed, operated and maintained by qualified personnel **ONLY**.

Improper installation can damage your system or cause injury or death.

Comply with all applicable codes.

MEX (55) 53 63 23 31 MTY (81) 83 54 10 18
QRO (442) 1 95 72 60 ventas@industrialmagza.com

MAGZA
INDUSTRIAL
DIST. AUTORIZADO

Nexen Group, Inc.
560 Oak Grove Parkway
Vadnais Heights, Minnesota 55127

ISO 9001 Certified

Copyright 2007 Nexen Group, Inc.

Table of Contents

Installation	4
Friction Facing Adjustment	6
Air Connections	7
Lubrication	7
Operational Modes	8
Maintenance	9
Parts Replacement	10
Replacement Parts	12
Parts List	12
Warranty	13

.....

INSTALLATION

DISC

1. Thoroughly inspect the tapered bore of the disc hub and tapered surface of the Q.D. bushing. Remove any dirt, grease, or foreign material. **Do not use lubricants for this installation.**
2. Insert the Q.D. bushing into the disc hub, aligning the untapped holes in the bushing flange with the tapped holes in the disc hub.
3. Insert the pull-up bolts and tighten to the recommended torque (See Tables 1 and 2).

NOTE: Runout is minimized if a dial indicator is used as the pull-up bolts are tightened. Place contact tip of the Dial Indicator on the machined surface of the Rotor to measure runout. Runout should be less than 0.254-0.381 mm [0.010-0.015 inches] (See Figure 1).

CAUTION

Exceeding the specified tightening torque creates excessive pressures in the hub. Leave a gap between the flange of the Q.D. bushing and the disc hub to ensure a proper fit of the Q.D. bushing onto the shaft or breakage can occur.

4. To remove the Q.D. bushing, remove the pull-up bolts and reinsert into the threaded holes. Tighten the pull-up bolts to push the disc off the Q.D. bushing.

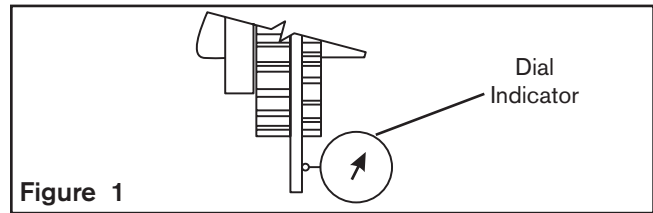

Figure 1

Table 1 (Non-Ventilated Discs)

DIAMETER mm [inches]	PRODUCT NO.	QD BUSHING	TORQUE Nm [ft-lb]
356 [14]	934202	E	81 [60]
406 [16]	934203	E	81 [60]
457 [18]	934204	J	182.5 [135]
508 [20]	934205	J	182.5 [135]
559 [22]	934206	J	182.5 [135]
610 [24]	934207	J	182.5 [135]

Table 2 (Ventilated Discs)

DIAMETER mm [inches]	PRODUCT NO.	QD BUSHING	TORQUE Nm [ft-lb]
464 [18.25]	934200	J	182.5 [135]
533 [21]	934300	J	182.5 [135]
610 [24]	934400	J	182.5 [135]

ACTUATOR

NOTE: The Spring Actuator Assembly is designed for extended service life. Due to this long product life, the assembly is permanently sealed to protect users from potentially dangerous spring forces. Do not attempt to service the actuator or remove the welds on the actuator bolts.

ALL SERVICE MUST BE PERFORMED BY TRAINED NEXEN PERSONNEL.

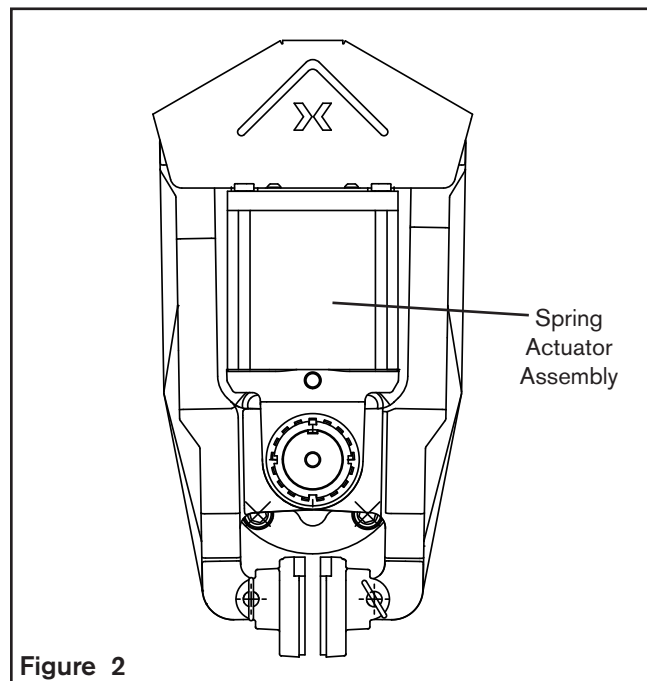

Figure 2

FRAME

NOTE: The VC500 Spring Actuator Assembly is factory calibrated to a 12.7 mm [0.500 in] wide brake disc. No adjustment is necessary when mating a disc of this size.

If using a thicker or thinner disc, offset shoes will be required. See the FRICTION FACING ADJUSTMENT section to readjust for a wider or thinner disc.

1. Release the brake with at least 4.1-4.8 bar [60-70 psi] air pressure.
2. Position the brake shoes on the disc and release the air pressure to lock the brake in place.

NOTE: Brakeshoes must be mounted with approximately 1.6 mm [1/16 inch] space between the outside edge of the shoe and the outer diameter of the disc.

2. Align the frame on a support (customer supplied) so the brake arms are parallel with the brake disc and the brake shoes are positioned at least 1.6 mm [1/16 inches] in from the disc edge.

NOTE: The support must be capable of sustaining loads produced during braking.

If using shims under the Frame (Item 1): Do not to warp the Frame when tightening the Cap Screws (customer supplied).

VERTICAL MOUNTING ONLY

NOTE: A special Bracket and Screw kit (Items 43 & 42) is supplied with each VC500 unit to be used in vertical mounting applications.

If mounting vertically, attach the Bracket before proceeding with step three:

Secure the Bracket to the bottom of the Actuator Mount (Item 4) with the supplied Screws. Position the Bracket with the notch straddling the arm of the frame to provide support (See Figure 4). Hold the Bracket tightly to the frame, and tighten the Screws to create a hard stop.

3. Release the VC500 from the disc.
4. Tighten the Cap Screws (customer supplied) and the Lock Washers (Item 20) to 67.8 Nm [50 ft-lb] torque (See Figure 3).

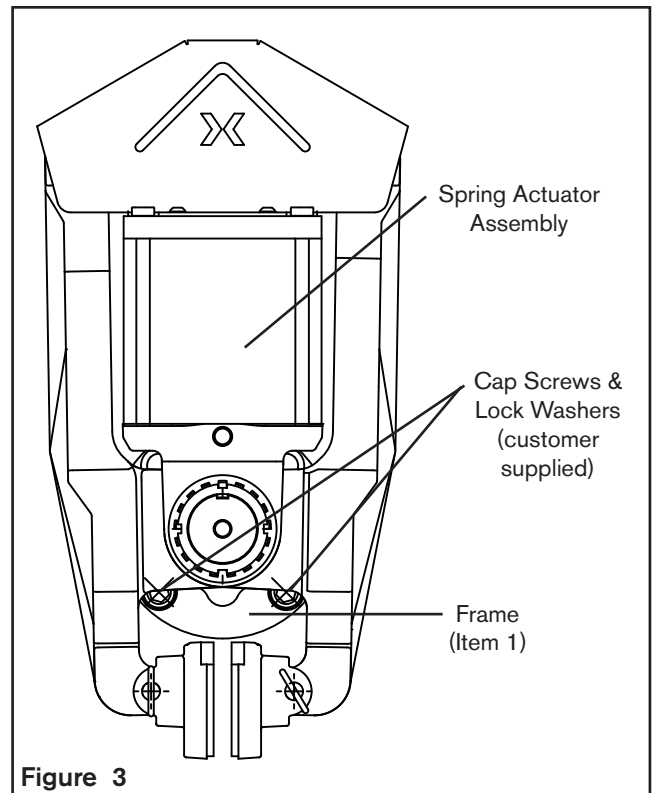

Figure 3

CAUTION

The Cap Screws (Item 17) must sustain the loads produced by the mounting torque. The torque rating specified in Tables 1 & 2 allows a significant load safety factor. **DO NOT EXCEED TORQUE LIMITS SPECIFIED FOR THE CAP SCREWS.**

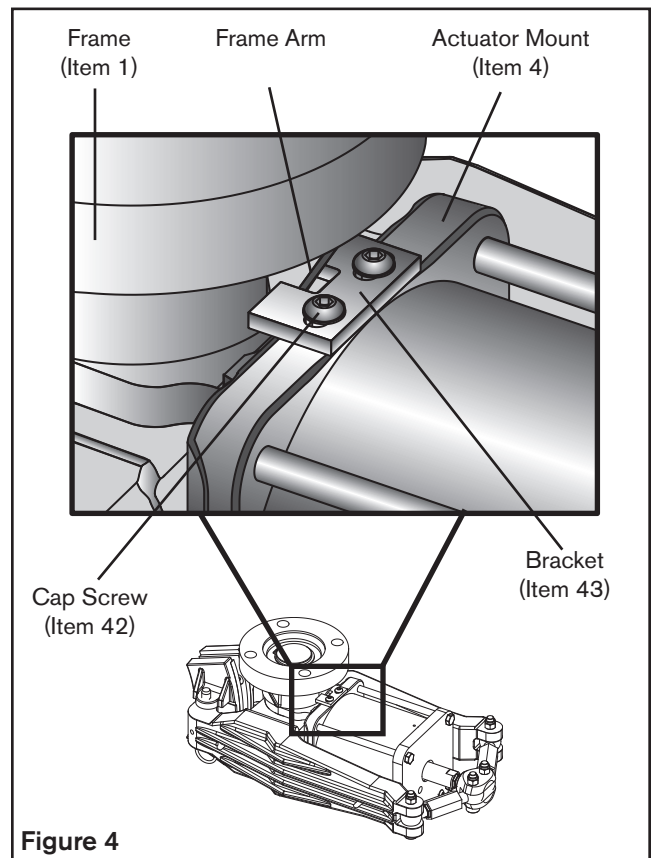

Figure 4

FRICION FACING ADJUSTMENT

NOTE: The VC500 Spring Actuator Assembly is factory calibrated to a 12.7 mm [0.500 in] wide brake disc. No adjustment is necessary when mating to a disc of this size. If using a thicker or thinner disc, offset shoes will be required.



WARNING

Do not wear facings down within 0.762 mm [0.030 in] of the iron facing shoe. Loss of clamping force and machine damage will result. Monitor facing wear closely and replace before worn to this dimension.

Adjustment of linkage is required for any disc above or below 12.4 mm [0.500 in] thick. Loss of torque or failure of the manual release function may result.

1. If the brake is mounted and clamping on the disc, apply ≥ 4.1 bar (≥ 60 psi) to release the spring actuator force from the linkage. The brake must be disengaged and unloaded for linkage adjustment (See Warning note to the right).

NOTE: Brake shoes and detent pins must be installed in order to perform the following procedure.

2. Remove the brake guard by removing cap screws (Item 34) (See Figure 5).
3. Remove only the center rod ends (Item 17 & 16) from the clevis (Item 14) by removing the locking nuts (Item 18) and screws (Item 28).
4. Apply ≥ 4.1 bar (≥ 60 psi) to the spring actuator.
5. With the air pressure applied rotate the clevis (Item 14) until the rear end is 100.9 mm (3.97 in) away from the face of the actuator.
6. Insert the center rod ends (Items 16 & 17) back into the clevis (Item 14) and tighten the locking nuts (Item 18) to 45.2 Nm (435 in-lb).

Once the rod ends are installed, retighten the clevis jam nut (Item 19), apply servicable thread locker to jam nut and torque to 4.5 Nm (40 in-lb).

7. Clevis adjustment is now complete.
8. It is critical that the linkage assemblies are both equal length. To ensure this, adjust both linkages by rotating the turnbuckle until the spacing between the arm (Item 3) and the actuator cap (Item 10) is equal -- see drawing for clarification. This will create a starting point for the final facing adjustment.



WARNING

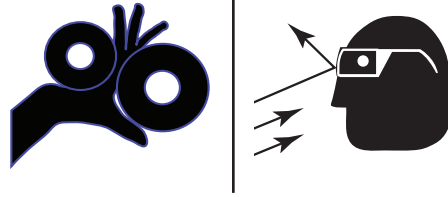

Do not allow air pressure to drop during brake linkage adjustment. High spring forces and possible pinch points require constant air pressure to prevent operator injury. Always keep hands and fingers out of the linkage assembly area when adjusting and actuating the brake.

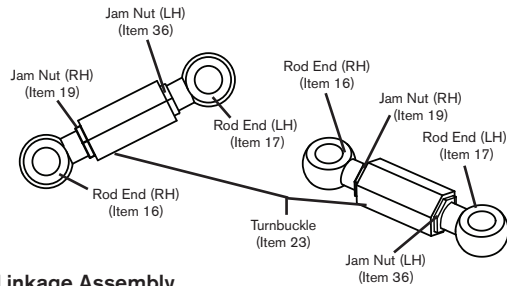

Linkage Assembly

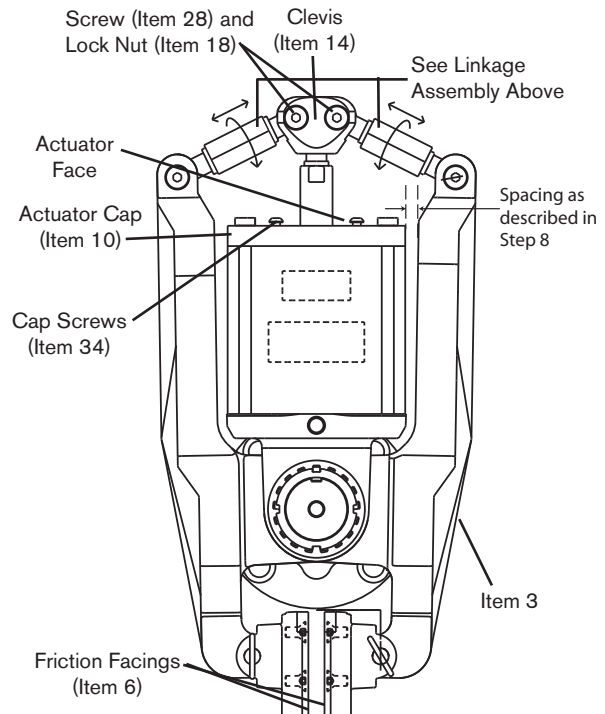

Figure 5

NOTE: DO NOT assume the thread lengths are equal on the rod ends. Use the actuator cap as a reference to equalize linkage length (as described in step 11).

- With ≥ 4.1 bar (≥ 60 psi) still applied, rotate the turnbuckles (Item 23) equally until contact is made between the facings (Item 6) and the brake disc. Then, back off 1/4 turn on each turnbuckle.

NOTE: The gap between the brake arm (Item 3) and the actuator cap (Item 10) should be equal on both sides. If not, continue to adjust turnbuckles until both arms are equally spaced and the facings (Item 6) are in contact with the brake disc.

- Carefully re-tighten the jam nuts (Item 19 and 26) to ensure that no turnbuckle movement is detected. Apply serviceable thread lock and torque jam nuts to 4.5 Nm (40 in-lb).

NOTE: LH jam nuts (Item 36) will have a paint mark to identify them from the RH thread nuts.

- Apply a serviceable thread lock to the cap screws (Items 34) and reinstall the brake guard (Item 24).

AIR CONNECTIONS

Pneumatically actuated devices require clean, pressure regulated, and lubricated air for maximum performance and long life. Your Nexen distributor carries filters, regulators, and lubricators specifically designed to operate with Nexen clutches, brakes, and valves.

Piping diagrams are included in this manual for a variety of braking functions. Refer to OPERATIONAL MODES for details.

CAUTION

Do not use rigid pipe or tubing when connecting directly to the Brake. Prevent unshielded air hoses from rubbing on metal surfaces or edges, as this will cause rapid deterioration of the hose.



WARNING

Actuator is spring loaded under extreme pressure. Do not disassemble Actuator. If Actuator malfunctions, replace the Actuator or contact Nexen. The turnbuckle assembly can be used to physically release the spring.

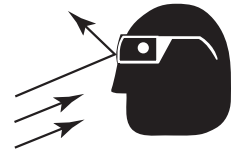

NOTE: The VC500 Caliper Brake has a .250-18 NPT air inlet port. A .250-18 NPT (male) and .250 ISO 7/1 (female) adapter is provided for metric plumbing applications.

LUBRICATION

All pivot points on the VC500 Caliper Brake use self-lubricated high PV bearings.

For tension control applications where the disc is held at elevated temperatures for extended periods, use a light machine oil on Bearings (Items 11, 12, 13, 22, 28, and 37) (See Figure 6).

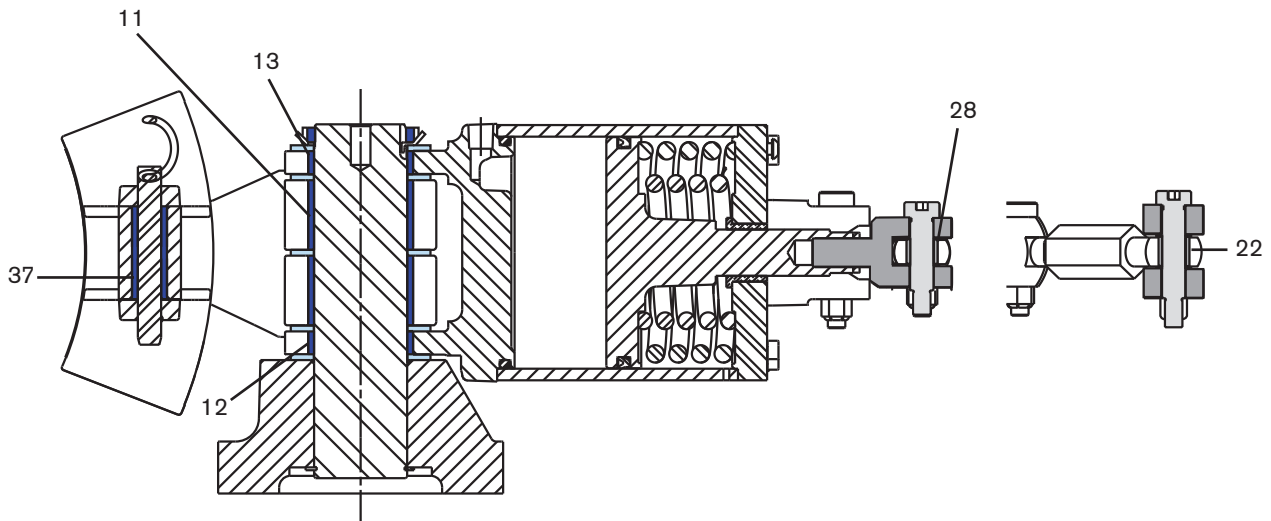

FIGURE 6

OPERATIONAL MODES

NORMAL SERVICE MODE

Below is a standard air brake control circuit. On-off air control is achieved by the 3-way valve. Torque is accomplished by the regulation of air pressure.

NOTE: Maximum operating pressure is 6.9 bar [100 psi] (See Figure 6).

NORMAL SPRING ENGAGED MODE

This mode is for occasional duty, non-cyclic applications only. A hold-off pressure of 4.1-4.8 bar [60-70 psi] is used to compress the spring inside the Actuator canister. A control signal is used to release the hold-off pressure, thus applying full spring-engaged torque to the brake (See Figure 7).

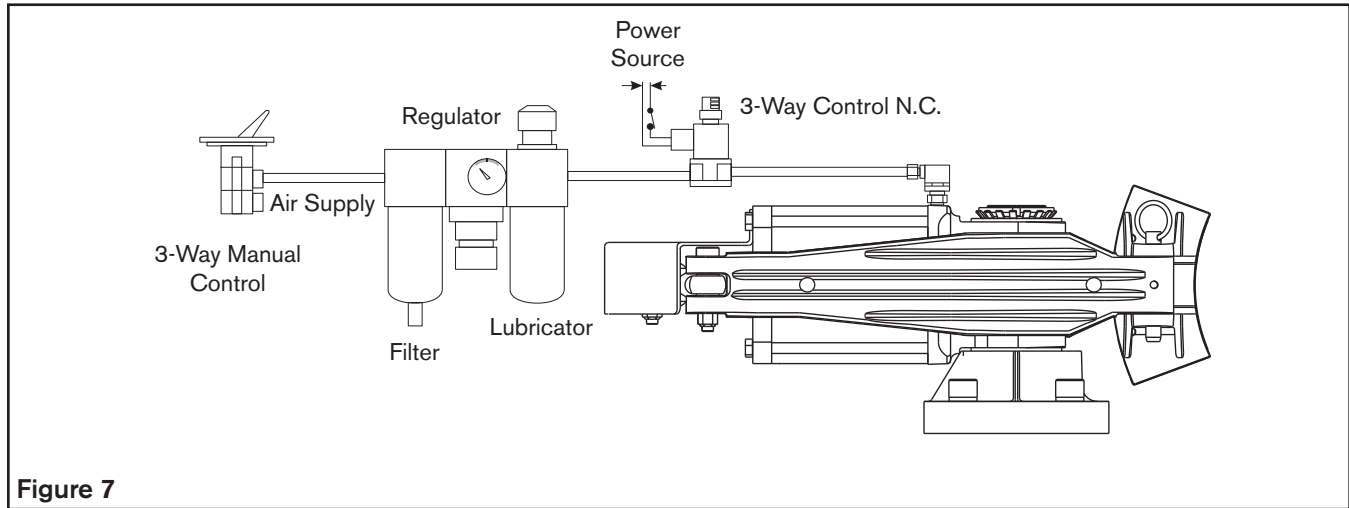

Figure 7

SPRING ENGAGED-DUAL AIR MODE

This mode allows the selection of any value of spring engaged torque (from zero to full scale) available with a particular disc size by relieving a percentage of the minimum Hold-Off pressure 4.1 bar [60 psi]. The remaining pressure, balanced against the spring force, reduces the output of the Actuator (See Figure 8).

EXAMPLE: A standard spring set brake with a 18 inch disc has a full rated spring engaged torque of 3,480 Nm [30,800 in-lb] when using the minimum hold-off pressure of 4.1 bar [60 psi]. If it is desired to have 60% of this torque or 2,016 Nm [18,000 in-lb], relieve the hold-off pressure 60 percent or 1.9 bar [36 psi], leaving 2.2 bar [24 psi] hold-off pressure.

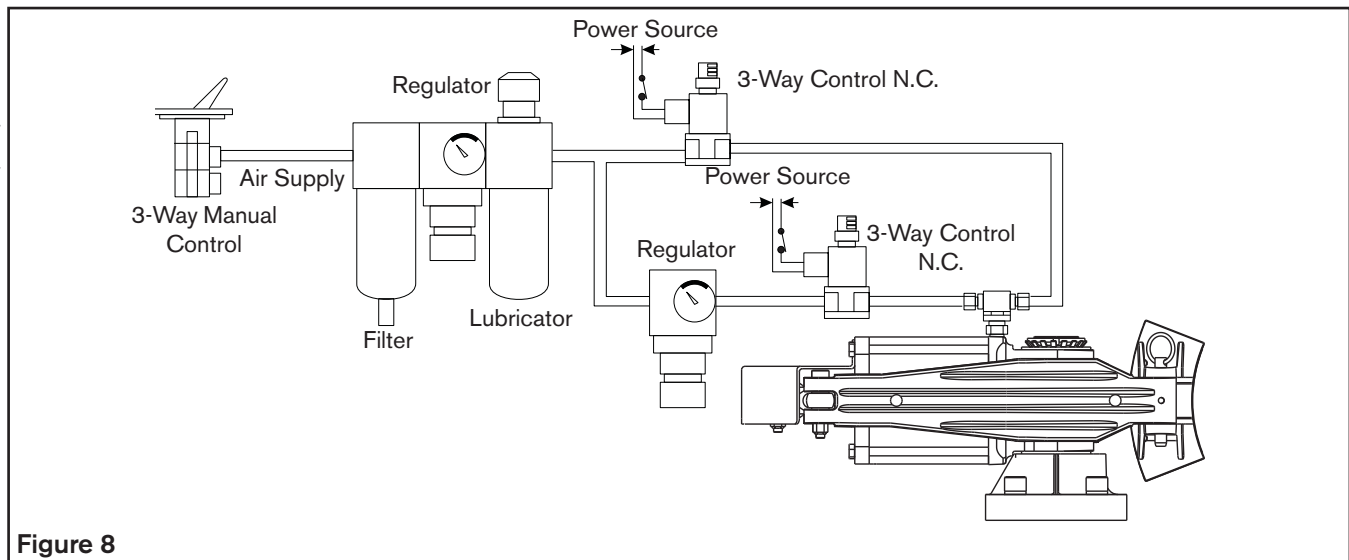

Figure 8

MANUAL RELEASE

To MANUALLY RELEASE THE BRAKE:

1. Remove brake guard (Item 24).
2. Using a thin 3/4" wrench, loosen the four jam nuts (Item 19) on the rod ends (Items 16 & 17).
3. Using a 1" wrench, rotate the turnbuckles (Item 23) equally until a noticeable gap is visible between the facings (Item 6) and the brake disc.

NOTE: Nexen recommends rotating the turnbuckles 1/2 turn at a time on each side until the brake is completely disengaged.

To REENGAGE THE BRAKE:

Follow instruction in friction facing adjustment section.



WARNING

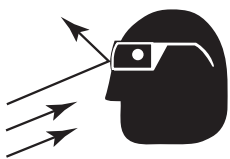

Actuator is spring loaded under extreme pressure. Do not disassemble Actuator. If Actuator malfunctions, replace the Actuator or contact Nexen.

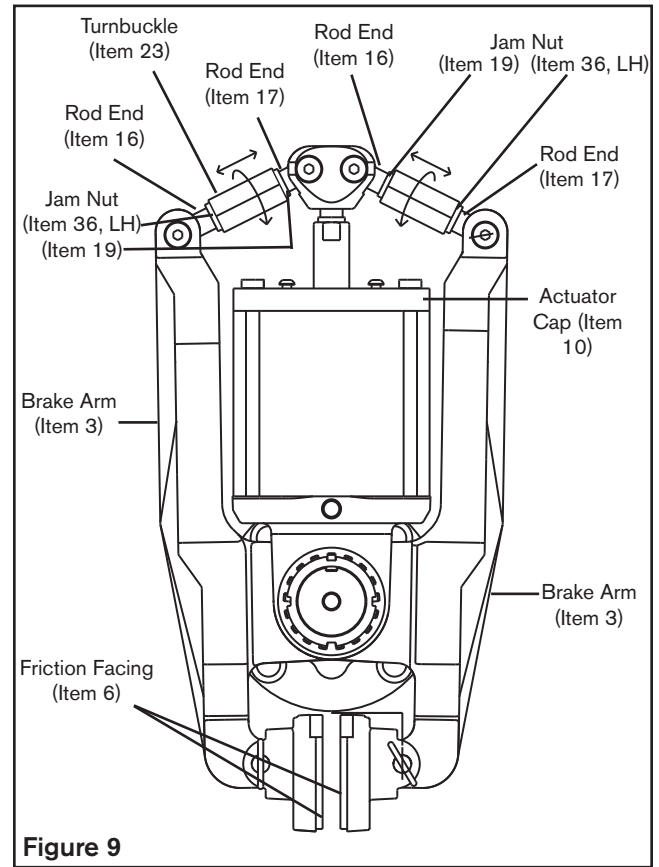

Figure 9

GENERAL

1. Adhere to the following bolt tightening torques (See Table 3).
2. Inspect Actuator exterior.
3. Check tightness of air line connections, and condition of all air lines. Replace worn or damaged air lines.
4. Inspect Friction Facings for wear. Replace before contact is made between shoes and brake disc.
5. Lubricate items requiring lubrication (See LUBRICATION).

TABLE 3

ITEM No.	DESCRIPTION	TORQUE Nm [ft-lb]
15	Machine Screw (friction facing)	12-16 [8-11]
19	Jam Nuts (linkage)	20-27 [15-20]
18	Lock Nuts (linkage)	44-57 [33-42]
33	Lock Nut (post)	finger tighten, then bend tab
36	Jam Nuts-LH (linkage)	20-27 [15-20]

PARTS REPLACEMENT

FRICITION FACINGS

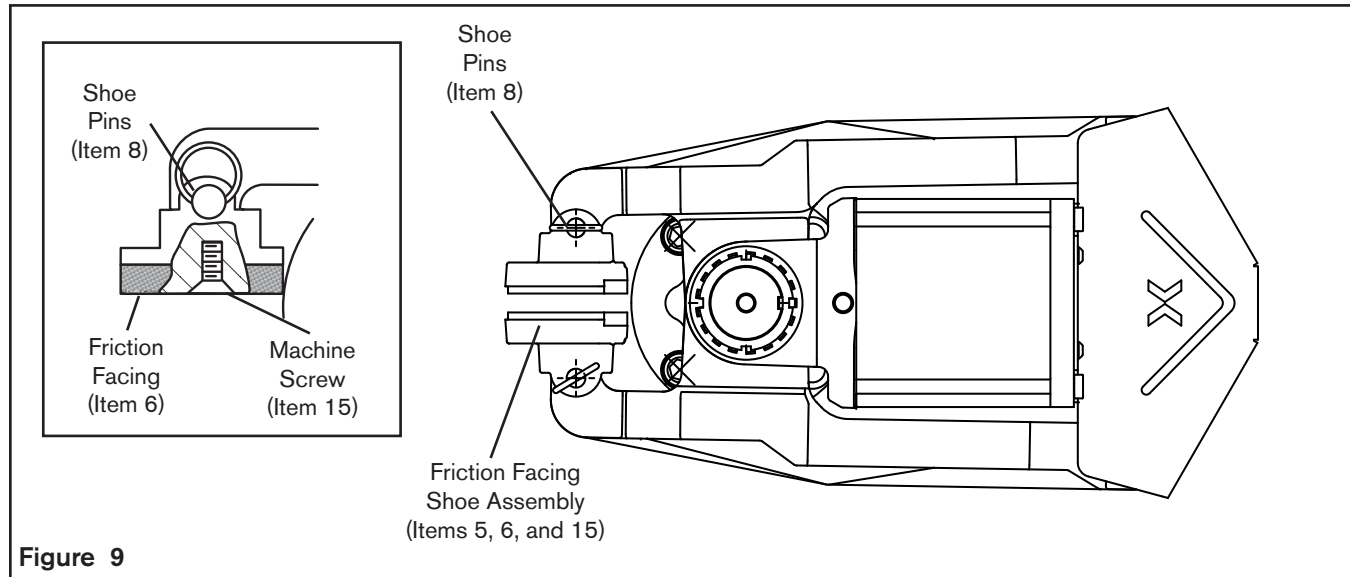

WARNING

Do not wear facings within 0.762 mm [0.030 in] of the iron facing shoe. Loss of clamping torque and machine damage will result. Monitor facing wear closely and replace before worn to this dimension.

Adjustment of linkage is required for any disc above or below 12.4 mm [0.500 in] thick. Loss of torque or failure of the manual release function may result.

NOTE: When replacing Friction Facings, inspect the Friction Disc for scoring or grooves. If necessary, the Friction Disc may be machined. A maximum of 0.76 mm [0.030 in] may be removed from each side of the Friction Disc before it is necessary to replace the Friction Disc.

1. Apply ≥ 4.1 bar [$m \geq 60$ psi] to open shoes or manually release the brake (See MANUAL RELEASE section for details).
2. Remove the shoe pins (Item 8).
3. Remove the friction facing shoe assembly (Items 5, 6, and 15).
4. Remove the old Machine Screws (Item 15) and old Friction Facings (Item 6).
5. Using new Machine Screws (Item 15), install new Friction Facings (Item 6) (See Figure 12).
6. Tighten the new Machine Screws (Item 15) to 12-16 Nm [8-11 ft-lb] torque.
7. Reinstall the Friction Facing Shoe Assembly (Items 5, 6, and 15) and Shoe Pins (Item 8).
8. Perform Friction Facing clearance adjustment (See FRICTION FACING ADJUSTMENT section for details).

NOTE: The Machine Screws are assembled with an anaerobic locking compound. To loosen the compound, insert a properly fitting screwdriver into the head of the Machine Screw and strike the screwdriver with a hammer. Never use an impact wrench to remove the Machine Screws.

BEARINGS

1. Remove Brake Guard (Item 24).
2. Apply ≥ 4.1 bar (≥ 60 psi) to open shoes or manually release the brake (See MANUAL RELEASE section).
3. Remove shoe pins (Item 8).
4. Remove the friction facing shoe assembly (Item 5, 6, and 15).
5. Remove air pressure from the brake.

NOTE: Nexen recommends removing the entire caliper brake assembly from the machine at this time.

6. Open the tab (Item 35) and remove the lock nut (Item 33).

NOTE: Mark the rod ends (Item 16 & 17) and turnbuckle assemblies (Item 23) to designate right and left side assemblies of the brake. Mark each assembly to designate arm (Item 3) and clevis side (Item 14).

7. Remove the rod ends (Item 16 & 17) from the clevis (Item 14) and the arm (Item 3) by removing the locking nuts (Item 18).

NOTE: Do not adjust the rod and turnbuckle assemblies while removed from the clevis.

8. Roll the caliper assembly on its side (or up-side-down) and pull the pin/base (Items 1 & 2) assembly out of the arms and actuator mount (Item 4).
9. Apply hand force to the arms (Item 3) to pry them out of the actuator mount.
10. Collect and inspect thrust bearings (Item 12 & 20). Replace if necessary.
11. Press the old bearings (11, 13, 22, & 37) out of the arms (Item 3) and rod ends (Items 16 & 17).
12. Press new bearings (Items 11, 13, 22, & 37) into the arms (Item 3) and rod ends (Items 16 & 17).
13. Still in the inverted position, reassemble the arm, bearing, and actuator mount assembly, carefully aligning the thrust bearings.
14. Slip the bottom thrust bearing on the pin/base assembly and insert the pin into the arm/actuator mount assembly.
15. Install final the thrust bearing, locking washer (Item 35), and lock nut (Item 33).
16. Finger tighten (Item 33) and bend the tab up on the lock washer to hold the lock nut in place.
17. Reinstall marked rod ends (Items 16 & 17) and turnbuckle assemblies (Item 23) to the proper sides of the brake.
18. Reinstall the caliper brake onto the machine and follow instructions in the FRICTION FACING

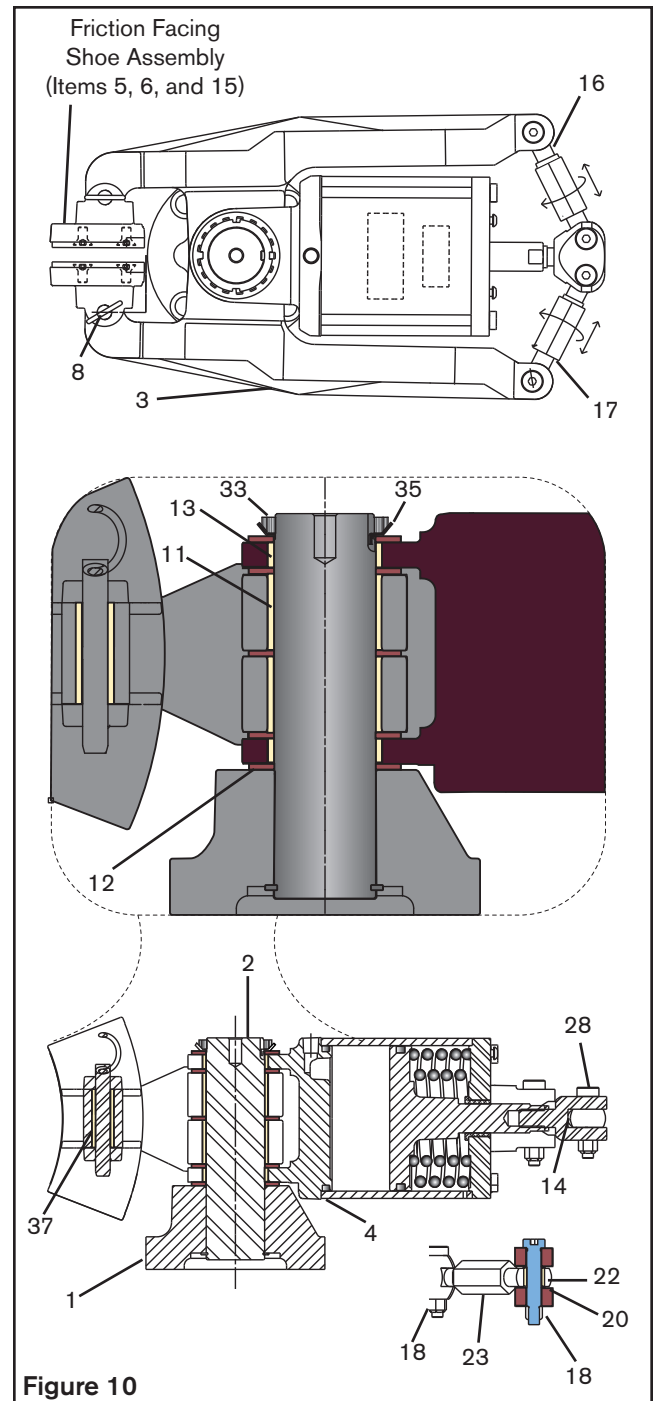
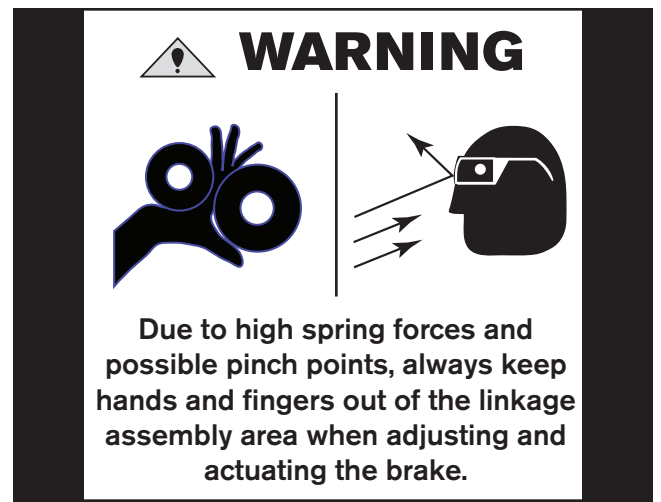

REPLACEMENT PARTS

The Item or balloon number for all Nexen products is used for part identification on all product parts lists, product price lists, unit assembly drawings, bills of materials, and instruction manuals.

When ordering replacement parts, specify model designation, item number, part description, and quantity. Purchase replacement parts through your local Nexen Distributor.

PARTS LIST

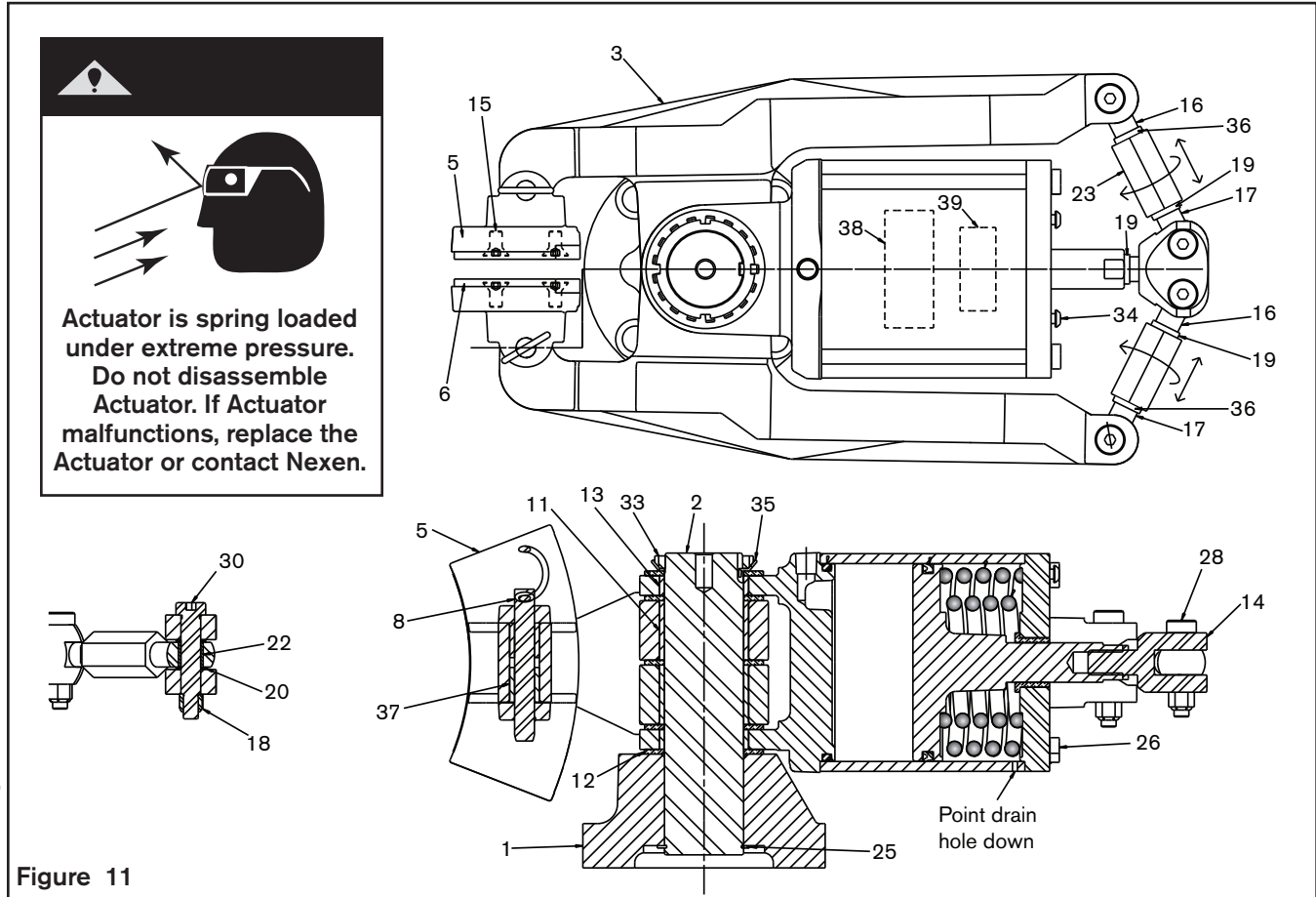

Figure 11

ITEM	DESCRIPTION	QTY
1	Pivot Pin Frame	1
2	Arm Pivot Pin	1
3	Brake Arm	2
5	Brake Shoe	2
6	Friction Facing	2
8	Detent Pin	2
11	Sleeve Bearing	2
12	Thrust Bearing	5
13	Sleeve Bearing (Actuator)	2
14	Clevis	1
15	Cap Screw	8
16	Solid Rod End (Right-Hand)	2
17	Solid Rod End (Left-Hand)	2
18	Hex Nut	18
19	Jam Nut	3

ITEM	DESCRIPTION	QTY
20	Thrust Washer	4
22	Sleeve Bearing	4
23	Turnbuckle	2
24	Guard	1
25	Retaining Ring	1
26	Hex Head Screw	4
28	Shoulder Screw	2
30	Shoulder Screw	2
33	Bearing Lock Nut	1
34	Cap Screw	2
35	Keyed Washer	1
36	Jam Nut (Left-Hand)	2
37	Sleeve Bearing	4
41	Air Inlet Adapter, 1/4 NPT, metric (not shown)	1

NOTE: The VC500 Caliper Brake has a .250-18 NPT air inlet port. A .250-18 NPT (male) and .250 ISO 7/1 (female) adapter is provided for metric plumbing applications.

WARRANTY

Warranties

Nexen warrants that the Products will be free from any defects in material or workmanship for a period of 12 months from the date of shipment. NEXEN MAKES NO OTHER WARRANTY, EXPRESS OR IMPLIED, AND ALL IMPLIED WARRANTIES, INCLUDING WITHOUT LIMITATION, IMPLIED WARRANTIES OF MERCHANTABILITY AND FITNESS FOR A PARTICULAR PURPOSE ARE HEREBY DISCLAIMED. This warranty applies only if (a) the Product has been installed, used and maintained in accordance with any applicable Nexen installation or maintenance manual for the Product; (b) the alleged defect is not attributable to normal wear and tear; (c) the Product has not been altered, misused or used for purposes other than those for which it was intended; and (d) Buyer has given written notice of the alleged defect to Nexen, and delivered the allegedly defective Product to Nexen, within one year of the date of shipment.

Exclusive Remedy

The exclusive remedy of the Buyer for any breach of the warranties set out above will be, at the sole discretion of Nexen, a repair or replacement with new, serviceably used or reconditioned Product, or issuance of credit in the amount of the purchase price paid to Nexen by the Buyer for the Products.

Limitation of Nexen's Liability

TO THE EXTENT PERMITTED BY LAW NEXEN SHALL HAVE NO LIABILITY TO BUYER OR ANY OTHER PERSON FOR INCIDENTAL DAMAGES, SPECIAL DAMAGES, CONSEQUENTIAL DAMAGES OR OTHER DAMAGES OF ANY KIND OR NATURE WHATSOEVER, WHETHER ARISING OUT OF BREACH OF WARRANTY OR OTHER BREACH OF CONTRACT, NEGLIGENCE OR OTHER TORT, OR OTHERWISE, EVEN IF NEXEN SHALL HAVE BEEN ADVISED OF THE POSSIBILITY OR LIKELIHOOD OF SUCH POTENTIAL LOSS OR DAMAGE. For all of the purposes hereof, the term "consequential damages" shall include lost profits, penalties, delay images, liquidated damages or other damages and liabilities which Buyer shall be obligated to pay or which Buyer may incur based upon, related to or arising out of its contracts with its customers or other third parties. In no event shall Nexen be liable for any amount of damages in excess of amounts paid by Buyer for Products or services as to which a breach of contract has been determined to exist. The parties expressly agree that the price for the Products and the services was determined in consideration of the limitation on damages set forth herein and such limitation has been specifically bargained for and constitutes an agreed allocation of risk which shall survive the determination of any court of competent jurisdiction that any remedy herein fails of its essential purpose.

Limitation of Damages

In no event shall Nexen be liable for any consequential, indirect, incidental, or special damages of any nature whatsoever, including without limitation, lost profits arising from the sale or use of the Products.

Warranty Claim Procedures

To make a claim under this warranty, the claimant must give written notice of the alleged defect to whom the Product was purchased from and deliver the Product to same within one year of the date on which the alleged defect first became apparent.

nexen[®]

Nexen Group, Inc.
560 Oak Grove Parkway
Vadnais Heights, MN 55127

800.843.7445
Fax: 651.286.1099
www.nexengroup.com

ISO 9001 Certified